



WIN POWER

***TP SERIES
SCR Power
Controllers***



***Instruction
Manual***

WINLING TECHNOLOGY LTD.

12F,NO.572,SEC.5 CHUNG SHIN RD., SAN CHUNG CITY, TAIPEI HSIEN, TAIWAN, R.O.C.

Tel: 886-2-29957702 Fax: 886-2-29957825

E-mail: win.ling@msa.hinet.net WEB: <http://www.winling.com.tw>

Wiring Diagrams:

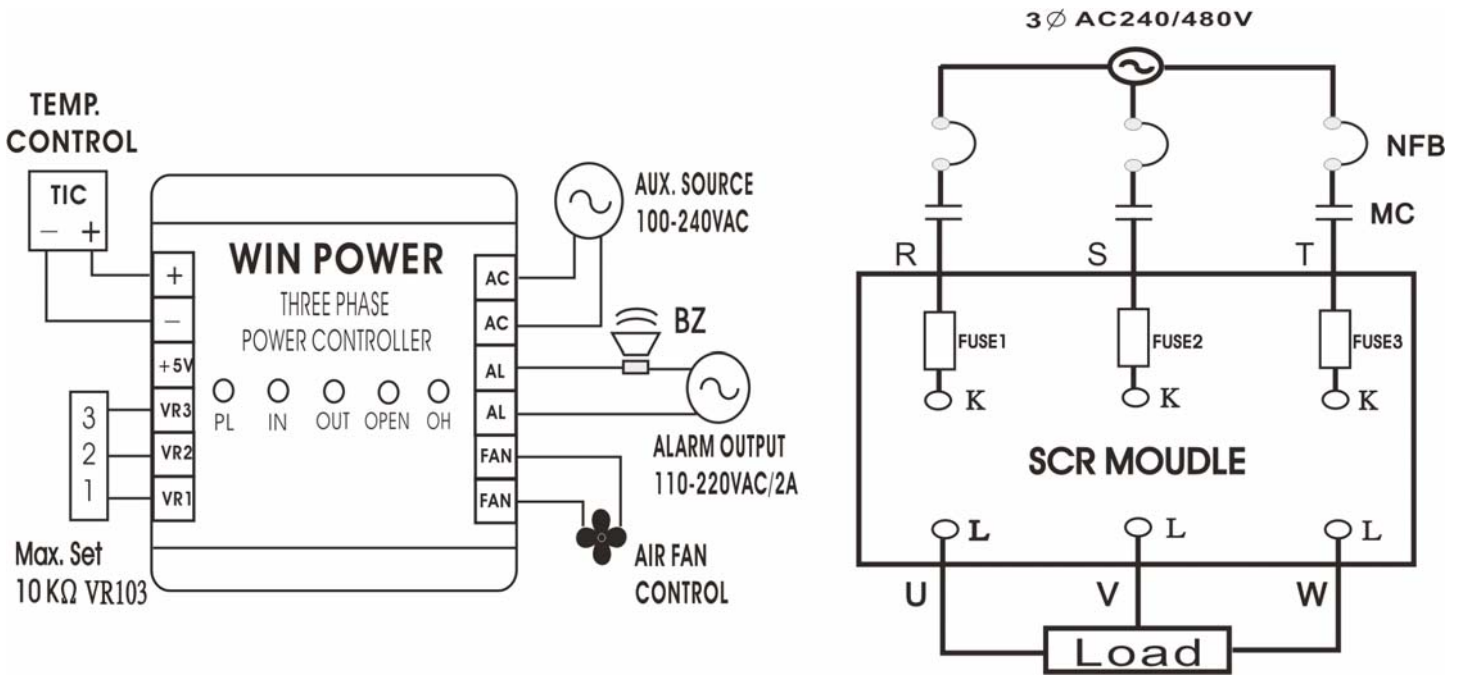

Input Signal Wiring Diagram:

1. All current or voltage signal
2. All current or voltage signal (with Max. Set adjustment)
3. Just manual adjustment (Any input signal of TIC +,-)
4. All current or voltage signal (Auto & Manu controller Replacement)

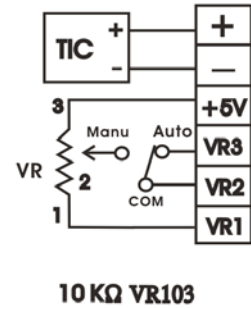
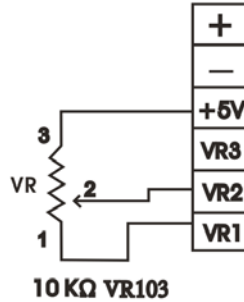
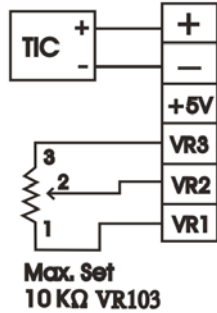
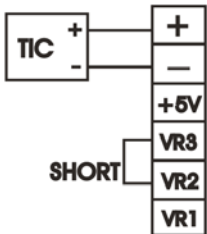

5. One TIC more SCRs

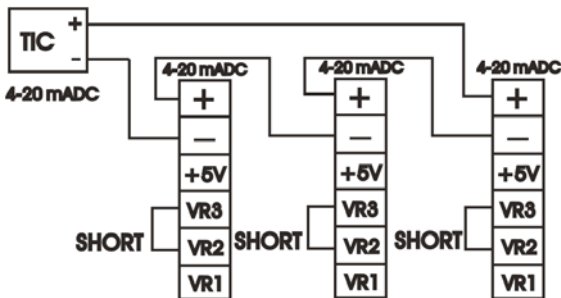

6. One TIC more SCRs (Each with Max set adjustment)

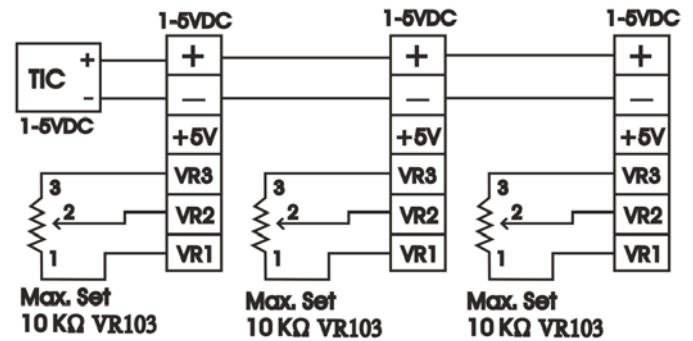

WIN POWER

Therr Phase power controller

TP SERIES OPERATING INSTRUCTIONS

Section 1. General Description

Introduction.

WIN POWER SCR Power Controllers are designed to regulate ac power to electrical heating processes, such as ovens, furnaces, heat sealers, transformers, etc. The controller accepts an input signal, such as 4-20 mA dc from some signal conditioning device, e.g., an temperature controller. For most processes, the combination of an temperature controller and SCR power controller will provide very accurate, automatic temperature control. For manual operation, a manual control option with a remote potentiometer is available.

Section 2. Firing Modes

Phase-Angle Control.

A phase-angle type SCR power controller works by delaying the trigger pulse to some point in the half cycle of the ac wave. This trigger point, from 0 to 180 degrees, is referred to as the phase angle. The SCR will turn on when triggered, and remain on for the rest of the half cycle. Increasing the control signal will cause the trigger pulse to occur earlier in the half cycle, thus delivering a greater portion of the wave to the load.

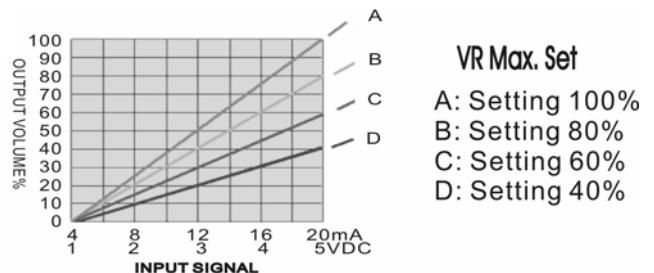
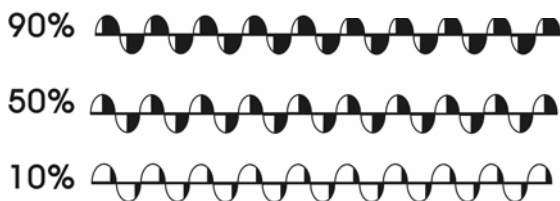

Because it provides an extremely fast response, phase-angle control should be used in low-mass element applications that require high switching speeds, such as tungsten elements, quartz lamps, hot wires and other loads subject to high inrush currents. (Note: Some RFI can be generated from the phase angle controller) SCR phase-angle power controllers are available with a soft-start timing option that provides a ramp to peak voltage, and are available with a voltage limit option that "clamps" output voltage to a level lower than the supply voltage.

Section 3. Installation

3.1 Mounting.

Mount the controller, with the heat sinks in a vertical position, in a reasonably cool location -- 50°C (122°F) maximum. Some space should be left above and below the unit to allow for air circulation. If the controller must be placed in an environment where the ambient temperature exceeds 50°C (122°F), it will be necessary to derate the unit. If derating is not possible, venting or an exhaust fan must be used to keep ambient temperatures at an acceptable level.

3.2 Wiring.

The wiring components of SCR power controllers consist of line voltage, heater load, and signal input. Follow the wiring diagrams on the following pages and the terminal labels on the unit

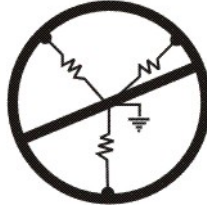

Wire gauge for power and load connections will vary depending on the size of the load. Standard electrical code procedures should be followed. Do not exceed the voltage and ampere ratings indicated on the controller's label. Before connecting the controller to a heater, we recommend that the heater be connected directly to the power line to ensure that the current rating is correct and that no shorts exist.

CAUTION

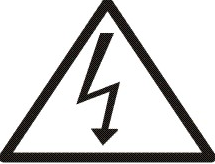

On Wye connected loads, do not connect the center terminal to the line or to the ground.

CAUTION:

	<p>Possible Shock Hazard -- Exposed high voltage exists on heat sinks and other parts of these units. To prevent possible electrocution, the controller must be locked in a secure enclosure during operation. Solid state devices do not completely remove power from the load, even in the OFF state. This leakage current presents a potential shock hazard at all unit and load terminals. All power must be completely off before servicing. Only qualified personnel should be allowed access.</p>
	<p>Possible Fire Hazard -- Because SCR power controls and associated equipment are not fail-safe devices, an approved temperature and/or pressure safety control should be used to ensure safe operation.</p>

General Specifications:

Inputs : 1-5vdc,0-10vdc,0-20mAdc,4-20 mAdc

Supply Voltage: TP24**:100~240; TP48**:340~480 Vac

(Phase connection not critical on 3-phase units)

Frequency: 50/60 Hz

Ambient Temperature: 0°C~50°C 90%RH for listed power ratings

Cooling: FAN

Protection: Sub-cycle, current-limiting fuse; transient voltage suppression

Load: Resistive, 3-phase - 3-wire wye or delta

Lamp Instructions:

PL Lamp (Green):AUX. Power Input

IN Lamp (Green): Input Instructions

OUT Lamp (Green): SCR Load Output

OPEN Lamp (Yellow): Main Source Power open / Fuse Open / Load Open

OH Lamp (Red): heat sinks Up 85°C