

(Resistive Loads Only)

- Extends Heater Life-Eliminates Thermal Shock.
- Optically Isolated.
- Capacity Up To 150 Amps.
- Diagnostic Indicators.
- Self-Synchronizing To Line Frequency.
- Isolated Heat Sinks.
- Compact Design.
- Full Protection Against Line Voltage Spikes.

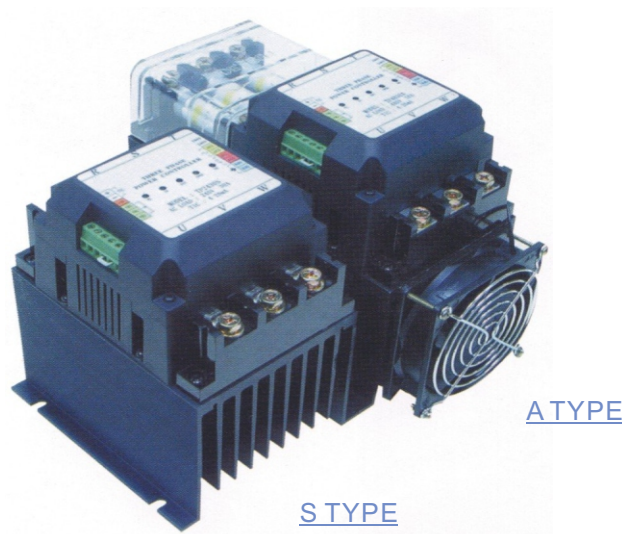

Drying, Wire and Cable, Foods Machinery, Power Metallurgy, Plastic Extrusion Machinery, UV, IR Drying Machinery, High Temperature Ceramic Furnace, Metallic Heating Treatment Drying Machinery, Plastic Leather Pasting, Chemical-heating Equipment And Power Type Voltage Output Adjustment Equipment

SPECIFICATIONS

Load Current Rating	20A~150A
Load Voltage	100~250VAC/200~480VAC
Aux. Power	100~250VAC
Input Type	0-20mA/4-20mA/0-5VDC/1-5VDC/0-10VDC
Min Load Current	0.6A
Off State Leakage Current	15mA (Max)
Power Consumption	5W (Max)
Input Frequency	50~60HZ
Input Resistance	DCA (250Ω) ,DCV (10KΩ)
Isolation Voltage	AC2500V (1 Min)
Alarm Relay Contact	2.0A
Operating Temperature	-10~82°C
Operating Humidity	95% RH
Storage Temperature	-10~60°C
Storage Humidity	95% RH
Soft Start	8.4sec
FAN ON/OFF Temperature	>50°C ON / <45°C OFF
HI Temperature Alarm	<82°C OFF / >73°C ON

Trigger Control

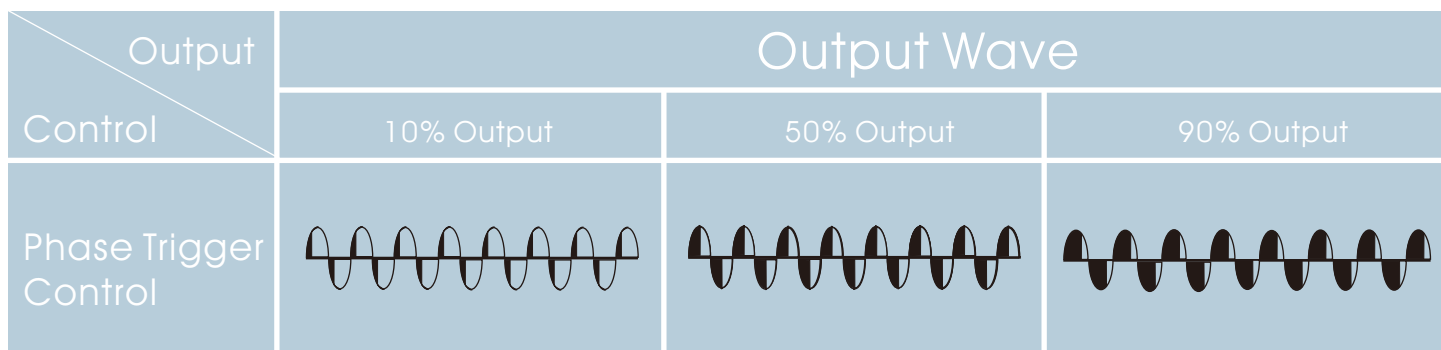

Order Model/Outside Dimension/Weight

Connection Diagram

MODEL: TP -

Type	TP	
Input Voltage	24	100~250VAC
	48	200~480VAC
Load Current	20	20A
	30	30A
	50	50A
	75	75A
	100	100A
	150	150A
Fuse Connection Model	A	Combination
	S	Separation
Input Type	-	
	A	0-20mA
	B	4-20mA
	C	0-5VDC
	D	1-5VDC
	E	0-10VDC
F	2-10VDC	
S	SPECIFIED	
	3	3P3W
	6	3P4W

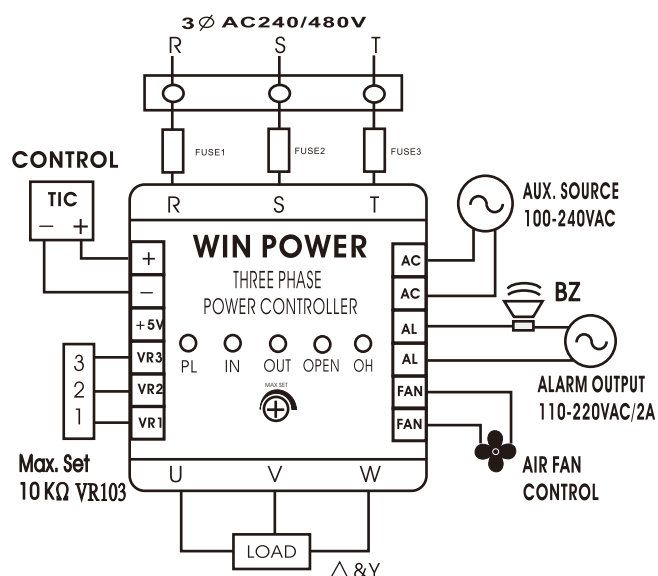

The the max output limit of
Via VR Switch Setting :

- A: Setting 100%
- B: Setting 80%
- C: Setting 60%
- D: Setting 40%

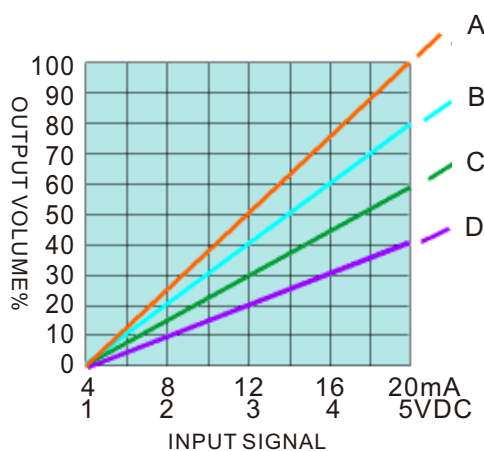

Model	S TYPE (L X W X H)mm/(Weight)kg	A TYPE (L X W X H)mm/(Weight)kg
20A	143X128X170mm/1.6kg	
30A	143X128X170mm/1.7kg	206X128X170mm/2.2kg
50A	173X128X170mm/2.2kg	236X128X170mm/2.9kg
75A	236X128X170mm/2.5kg	250X140X194mm/3.5kg
100A	250X140X194mm/3.0kg	250X140X194mm/3.5kg
120A	250X140X194mm/3.0kg	272X140X194mm/4.0kg
150A		305X140X194mm/4.5kg